



# FFF3210

Double ten litre fryer

## SPECIFICATIONS

POWER	2 x 8.4kW	<b>MODEL</b> FFF3210  ELECTRIC
VOLTAGE	380V - 50Hz - 3 Phase	
PACKAGING (W x D x H)	612 x 907 x 1140 (mm)	
UNIT (W x D x H)	512 x 807 x 1043 (mm)	
OIL VOLUME	2 x 10 (litre)	
NET WEIGHT	63kg	
GROSS WEIGHT	73kg	
SHIPPING VOLUME	0.60 m3	
PRODUCT OUTPUT	45 Kg per hour	

# FEATURES

MODEL: FFF3210

- Unit designed to compete in the rigorous and demanding environment of busy kitchens in the most popular chain stores, franchises and high end restaurants.
- Large diameter tilting stainless steel heating elements, with latch mechanism.
- Front mounted controls, ensure safe working practice.
- Insulated oil tanks for efficient heat retention.
- Operating temperature range of 50°C to 190°C. with safety cut-out thermostats mounted to the control panel.
- Adjustable leveling feet with castor wheels on the rear.
- Large drain valves and easy to remove drain tank for safe oil handling

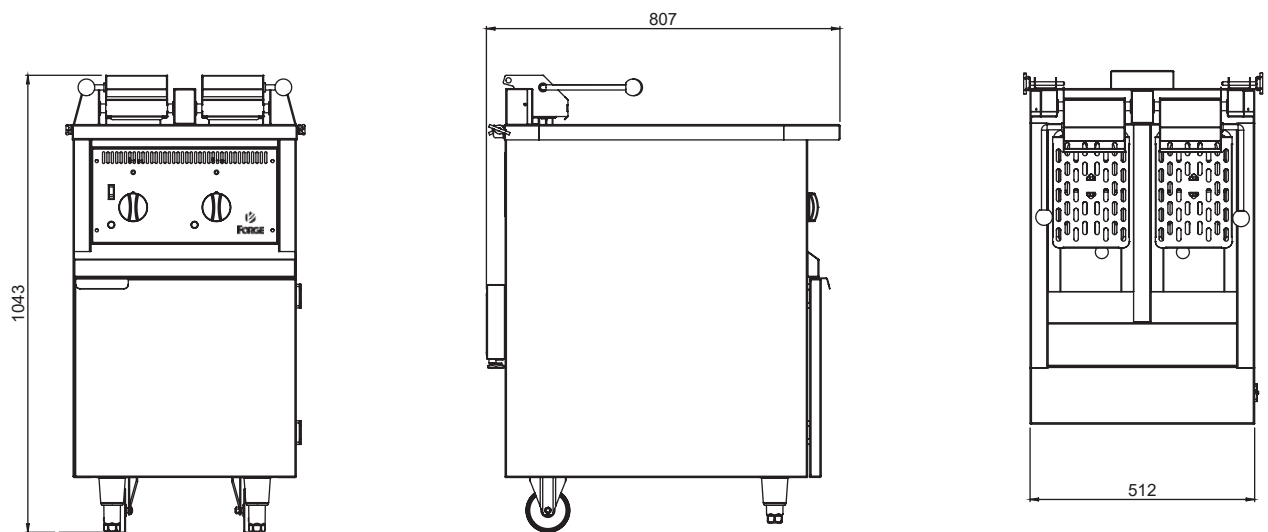

## NOTE

When viewing the appliance from the front in its usual operating position, the width (W) of the product is the total distance from left to right; the depth (D) of the product is the total distance from the front to the back; the height (H) is the total distance from the bottom of the product to the top. Pictures may vary from actual product.

## DISCLAIMER

Output performance figures quoted are dependent on various factors. Anvil reserves the right, without notice, to make changes and revisions to product specifications, materials and design, when we believe it will provide better performance, durability, and efficiency. Unit measurements may vary depending on point of reference.

