



# FGE3600

SOLID TOP GRILLER 600mm

## SPECIFICATIONS

POWER	6kW	<b>MODEL</b>
VOLTAGE	380V - 50Hz - 3Phase	
PACKAGING (W x D x H)	695 x 880 x 1160 (mm)	FGE3600
UNIT (W x D x H)	618 x 765 x 1000 (mm)	 <b>ELECTRIC</b>
GRILL AREA	614 x 550 (mm)	
NET WEIGHT	76kg	
GROSS WEIGHT	80kg	
SHIPPING VOLUME SURFACE	0.71m3 Flat	



# FEATURES

MODEL: FGE3600

- Unit designed to compete in the rigorous and demanding environment of busy kitchens in the most popular chain stores, franchises and high end restaurants.
- Heavy duty Robert Shaw Thermostats for reliable and effective heating control over entire surface.
- Heavy Duty 12mm thick cooking surface for effective heat distribution and retention.
- Rear castors to easily move for cleaning
- Heavy Duty fascia (temperature scale) design to inspire confidence in units hard working characteristics.
- Solid stainless steel construction, designed to be hard working, durable, easy to clean, maintain and service.

**NOTE:**

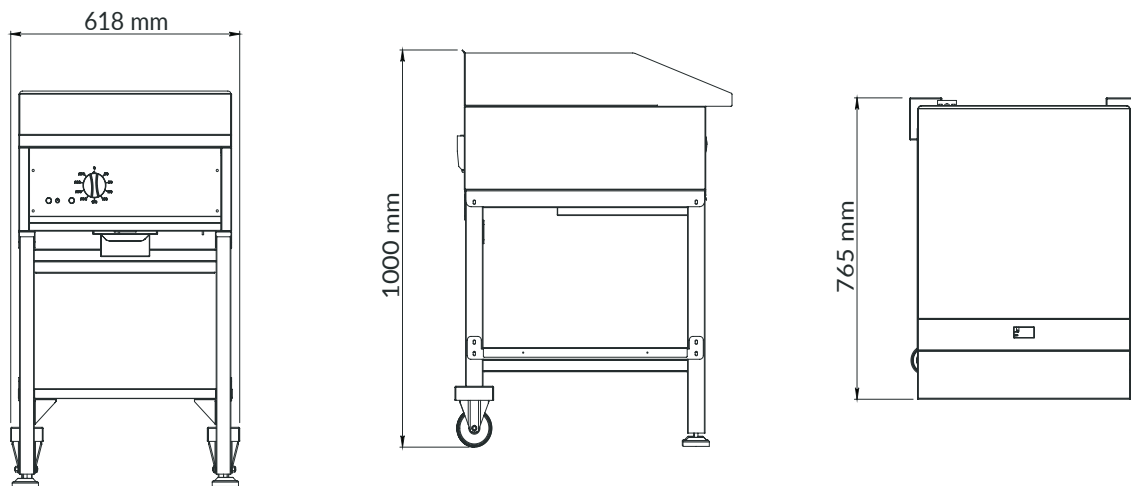

**NOTE**

When viewing the appliance from the front in its usual operating position, the width (W) of the product is the total distance from left to right; the depth (D) of the product is the total distance from the front to the back; the height (H) is the total distance from the bottom of the product to the top. Pictures may vary from actual product.

**DISCLAIMER**

Output performance figures quoted are dependant on various factors. Anvil reserves the right, without notice, to make changes and revisions to product specifications, materials and design, when we believe it will provide better performance, durability, and efficiency. Unit measurements may vary depending on point of reference.

