



FGR3600

RADIANT GRILLER 600mm

SPECIFICATIONS

OUTPUT	56 000 BTU	MODEL FGR3600 
PACKAGING (W x D x H)	695 x 880 x 1160 (mm)	
UNIT (W x D x H)	618 x 800 x 1028 (mm)	
NET WEIGHT	76kg	
GROSS WEIGHT	80kg	
SHIPPING VOLUME	0.71m ³	
SURFACE GRID SIZE	Ribbed Grates 300 x 150 (mm)	
GRILL AREA	614 x 550 (mm)	

AVAILABLE IN: LPG & Ngas



ALL FORGE EQUIPMENT COMES WITH A TWO YEAR WARRANTY ON COMPONENTS AND DEFECTIVE WORKMANSHIP.

FEATURES

MODEL: FGR3600

- New unit designed to compete in the rigorous and demanding environment of busy kitchens in the most popular chain stores, franchises and high end restaurants.
 - Gas approved ball valves for reliable and durable control.
 - Sturdy, stainless steel integrated stand with bottom shelf for additional storage.
 - Rear castors to easily move for cleaning
 - Hard wearing and long lasting heavy cast iron grates and radiants that retain and radiate heat for efficient grilling.
 - Powerful 14 000 BTU burners, for even and effective heat distribution.
 - Piezoelectric starter
- NOTE:**
- Heavy duty gas products to be connected by approved gas installer
 - No gas regulator supplied

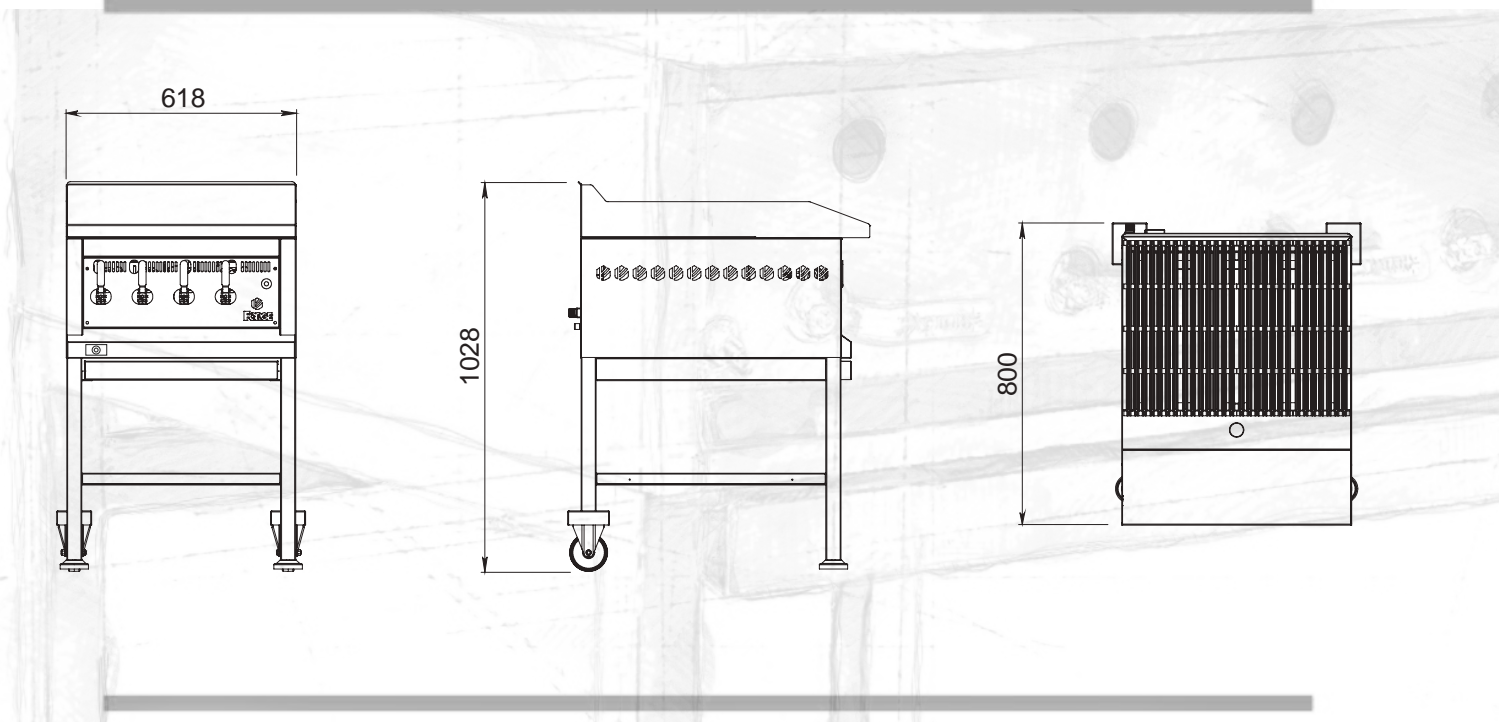

NOTE

When viewing the appliance from the front in its usual operating position, the width (W) of the product is the total distance from left to right; the depth (D) of the product is the total distance from the front to the back; the height (H) is the total distance from the bottom of the product to the top. Pictures may vary from actual product.

DISCLAIMER

Output performance figures quoted are dependant on various factors. Anvil reserves the right, without notice, to make changes and revisions to product specifications, materials and design, when we believe it will provide better performance, durability, and efficiency. Unit measurements may vary depending on point of reference.

