



# FIS0001

## INDUCTION COOKER 4 PLATE

### SPECIFICATIONS

<b>POWER</b>	4 x 5 kW	<b>MODEL</b>
<b>VOLTAGE</b>	380V - 50Hz -3 Phase	
<b>PACKAGING (W x D x H)</b>	955 x 850 x 1120 (mm)	FIS0001
<b>UNIT (W x D x H)</b>	900 x 765 x 915 (mm)	 <b>ELECTRIC</b>
<b>NET WEIGHT</b>	72.5kg	
<b>GROSS WEIGHT</b>	93kg	
<b>SHIPPING VOLUME</b>	0.90m <sup>3</sup>	
<b>SURFACE</b>	Flat	



# FEATURES

MODEL: FIS0001

- Heavy duty induction stove built for high demand commercial kitchens.
- Dual glass surface with two 5kW induction coils per plate, spaced to accommodate larger pots.
- Stainless steel construction with front mounted controls for safe operation.
- Heats only the pan and its contents, keeping the tempered glass surface cool and safe.
- Rapid on demand heating with precise control, using up to 30% less electricity than traditional electric cooking.

**NOTE:**

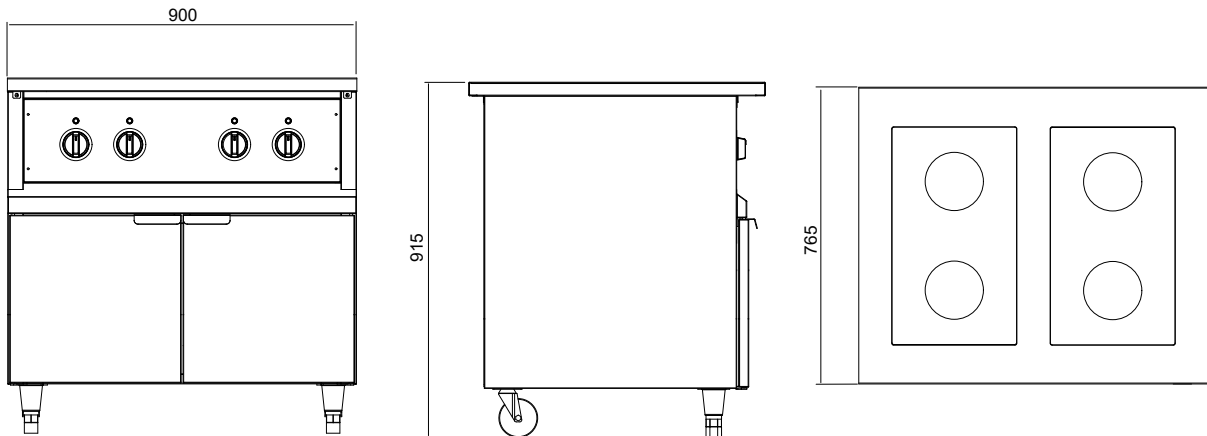

**NOTE**

When viewing the appliance from the front in its usual operating position, the width (W) of the product is the total distance from left to right; the depth (D) of the product is the total distance from the front to the back; the height (H) is the total distance from the bottom of the product to the top. Pictures may vary from actual product.

**DISCLAIMER**

Output performance figures quoted are dependant on various factors. Anvil reserves the right, without notice, to make changes and revisions to product specifications, materials and design, when we believe it will provide better performance, durability, and efficiency. Unit measurements may vary depending on point of reference.

