



FSP0003

SOLID PLATE STOVE 3 BURNER

SPECIFICATIONS

OUTPUT	42 000 BTU
PACKAGING (W x D x H)	1200 x 865 x 1090 (mm)
UNIT (W x D x H)	1102 x 765 x 1000 (mm)
NET WEIGHT	129kg
GROSS WEIGHT	139kg
SHIPPING VOLUME	1.13m ³
SURFACE	Flat
COOKING AREA	969 x 537 (mm)

MODEL

FSP0003



AVAILABLE IN: LPG & Ngas



ALL FORGE EQUIPMENT COMES WITH A TWO YEAR WARRANTY ON COMPONENTS AND DEFECTIVE WORKMANSHIP.

FEATURES

MODEL: FSP0003

- New unit designed to compete in the rigorous and demanding environment of busy kitchens in the most popular chain stores, franchises and high end restaurants.
- Gas approved control valves for reliable and durable control.
- Sturdy, stainless steel stand with bottom shelf for additional storage.
- Rear castors to easily move for cleaning
- Powerful 14 000 BTU burners, for even and effective heat distribution.
- Solid stainless steel construction, designed to be hard working, durable, easy to clean, maintain and service.
- Heavy Duty 16mm thick stove plates for effective heat distribution and retention

NOTE:

- Heavy duty gas products to be connected by approved gas installer
- No gas regulator supplied

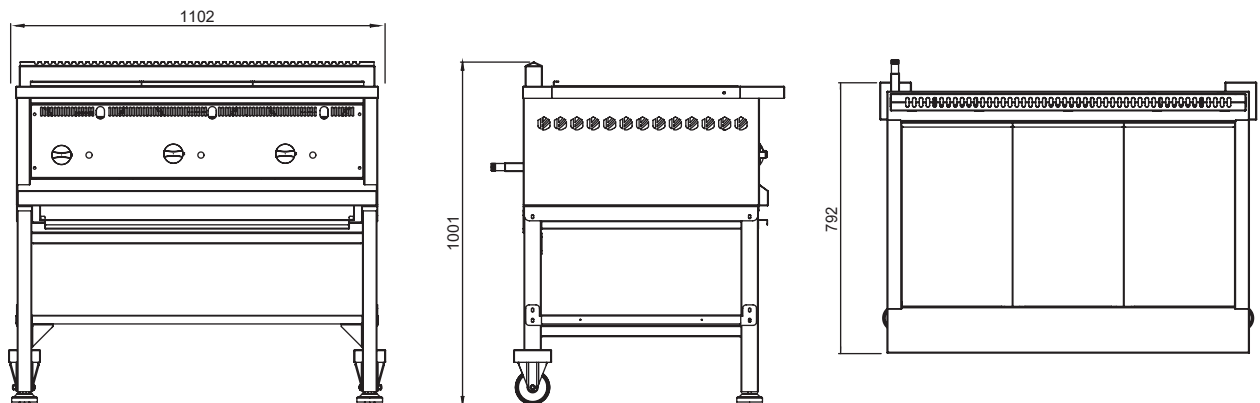

NOTE

When viewing the appliance from the front in its usual operating position, the width (W) of the product is the total distance from left to right; the depth (D) of the product is the total distance from the front to the back; the height (H) is the total distance from the bottom of the product to the top. Pictures may vary from actual product.

DISCLAIMER

Output performance figures quoted are dependant on various factors. Anvil reserves the right, without notice, to make changes and revisions to product specifications, materials and design, when we believe it will provide better performance, durability, and efficiency. Unit measurements may vary depending on point of reference.

