



# FSP1003

## SOLID PLATE STOVE ELECTRIC

### SPECIFICATIONS

POWER	12kW	<b>MODEL</b>
VOLTAGE	380V - 50Hz - 3Phase	
PACKAGING (W x D x H)	1200 x 865 x 1090 (mm)	FSP1003
UNIT (W x D x H)	1102 x 765 x 1000 (mm)	 <b>ELECTRIC</b>
COOKING AREA	969 x 537 (mm)	
NET WEIGHT	76kg	
GROSS WEIGHT	80kg	
SHIPPING VOLUME	1.13m <sup>3</sup>	
SURFACE	Flat	



# FEATURES

MODEL: FSP1003

- New unit designed to compete in the rigorous and demanding environment of busy kitchens in the most popular chain stores, franchises and high end restaurants.
- Heavy duty Robert Shaw control thermostats for reliable and durable control.
- Sturdy, stainless steel stand with bottom shelf for additional storage.
- Rear castors to easily move for cleaning
- Powerful 4 kW heating elements, for even and effective heat distribution.
- Solid stainless steel construction, designed to be hard working, durable, easy to clean, maintain and service.
- Heavy Duty 16mm thick stove plates for effective heat distribution and retention

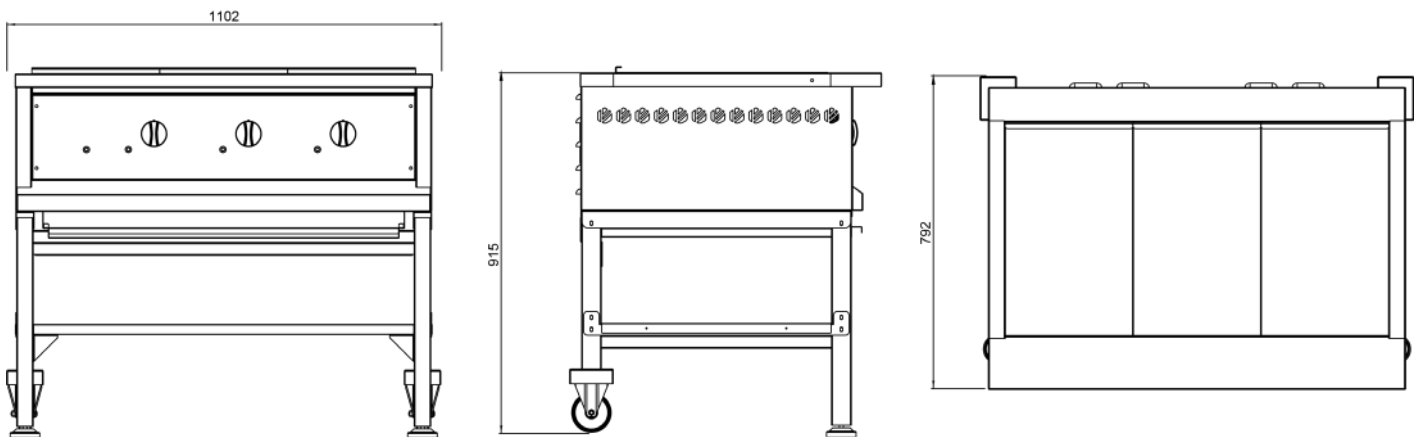

## NOTE

When viewing the appliance from the front in its usual operating position, the width (W) of the product is the total distance from left to right; the depth (D) of the product is the total distance from the front to the back; the height (H) is the total distance from the bottom of the product to the top. Pictures may vary from actual product.

## DISCLAIMER

Output performance figures quoted are dependant on various factors. Anvil reserves the right, without notice, to make changes and revisions to product specifications, materials and design, when we believe it will provide better performance, durability, and efficiency. Unit measurements may vary depending on point of reference.

