



# HOF2000

## SPEED CHEF OVEN

### SPECIFICATIONS

POWER	3.3kW	<b>MODEL</b>
VOLTAGE	230V - 50Hz - 1Phase	
PACKAGING (W x D x H)	613 x 601 x 433 (mm)	<b>HOF2000</b>
UNIT (W x D x H)	490 x 538 x 361 (mm)	
CAPACITY	8.6 Lt.	 <b>ELECTRIC</b>
NET WEIGHT	40kg	
GROSS WEIGHT	48kg	
SHIPPING VOLUME	0.15m3	
STOCK MENU	1728 items	

# FEATURES

MODEL: HOF0001

- Cooks product 15 times faster than conventional countertop ovens.
- Intuitive programmable touchscreen controls ensure consistent results.
- Certified ventless technology is perfect for front of house operation.
- Microwave, impinged hot air and convection technologies combine for rapid, even cooking with crisp, moist results.
- Constructed with robust stainless steel exterior and oven cavity for durability and effortless cleaning.

**NOTE:**

Includes 1 x S/Steel tray,  
1 x Solid Teflon basket,  
1 x mesh Teflon basket,  
1 x Oven shovel.

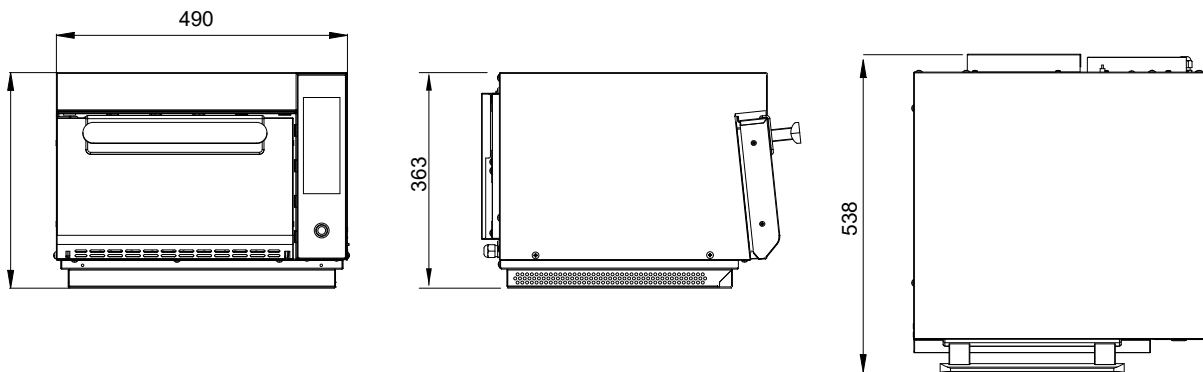

**NOTE**

When viewing the appliance from the front in its usual operating position, the width (W) of the product is the total distance from left to right; the depth (D) of the product is the total distance from the front to the back; the height (H) is the total distance from the bottom of the product to the top. Pictures may vary from actual product.

**DISCLAIMER**

Output performance figures quoted are dependant on various factors. Anvil reserves the right, without notice, to make changes and revisions to product specifications, materials and design, when we believe it will provide better performance, durability, and efficiency. Unit measurements may vary depending on point of reference.

